

Direct Contact Aqueous Ozone RTE Meat Processing

A Case Study

presented by

DEL Ozone

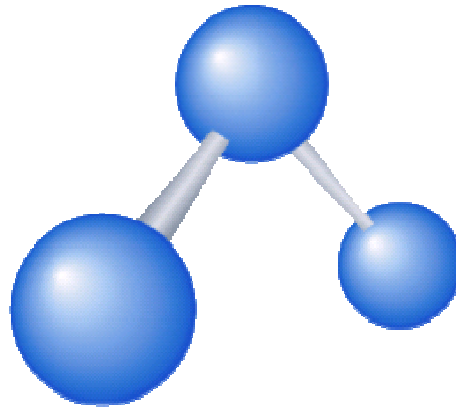

Overview

- **Validations and regulatory review**
- **Benefits of ozone in RTE meat processing**
- **Case study – applications and results**
- **Additional case studies summary**

Ozone Surface Sanitation

NSF Third-Party Validation

- **NSF studies of this Ozone system include the following EPA requirements:**
 - Antimicrobial efficacy data (Disinfectant Technical Science Section DIS/TSS - AOAC methods)
 - Toxicologic profiles
 - Environmental impact information
 - Specific label information/technical literature that detail recommended use of applications and directions

Ozone Surface Sanitation

NSF Third-Party Validation

- **NSF Test Results For Antimicrobial Efficacy**

- Ozone-Enriched Water at 2.0 PPM

- Bacteria

- **E. coli** 5 log reduction (99.999%)
- Listeria 4 log reduction (99.99%)
- **Salmonella** 6 log reduction (99.9999%)
- **Staphylococcus** 6 log reduction (99.9999%)
- **Pseudomonas** 6 log reduction (99.9999%)
- Campylobacter 4 log reduction (99.99%)

- Fungi

- Aspergillus 4 log reduction (99.99%)
- Brettanomyces 4 log reduction (99.99%)
- **Trichophyton** 6 log reduction (99.9999%)



Ozone Direct Product Sanitation RTE Post-Lethality Treatment Guidelines

- **Ozone Antimicrobial Agent Approval - FSIS Directive 7120.1 12/17/02**
 - “The attachment below identifies the substances that have been accepted since January 2000 by FSIS as safe and suitable for use in the production of meat and poultry products.”
 - *(Attachment 1) Antimicrobial*
 - *Ozone*
 - *All Meat and Poultry Products*
 - *Reference 21 CFR § 173.368*

Ozone Direct Product Sanitation RTE Post-Lethality Treatment Guidelines

- **FSIS Final Rule 68 FR 34207 (2003)** – Amends its regulations to require that RTE establishments producing certain RTE meat and poultry products prevent product adulteration by the pathogenic environmental contaminant *L. monocytogenes* (9 CFR 430.1 sets definitions)
- **FSIS Directive 10,240.4 (2003)** – Instructions for verifying whether these establishments are in compliance with Rule 68 FR 34207

Ozone Direct Product Sanitation

RTE Post-Lethality Treatment Guidelines

- **Compliance Guidelines To Control *Listeria Monocytogenes* in Post-Lethality Exposed Ready-To-Eat Meat And Poultry Products**
 - **Alternative 2** – Use of a post-lethality treatment (which may also be an antimicrobial agent or process) that reduces or eliminates microorganisms on the product OR an antimicrobial agent or process that suppresses or limits the growth of *L. monocytogenes*. *Requires quarterly monitoring.*
- **University of Wisconsin, Madison Validation Study (2004)**
 - Ham, salami, meatloaf, natural casing wieners, skinless wieners
 - 1.0 to 2.4 log reductions of *L. monocytogenes* demonstrated (dependent on product) **0.6 PPM DO₃ @ 30 Seconds (CT 0.3)**
 - Results demonstrated that the “Delzone system is an effective post-lethality treatment against *L. monocytogenes* on RTE meat products”

Ozone Sanitation

Benefits in RTE Meat Processing

- **The aqueous ozone system can perform double-duty:**
 - Surface sanitation / product treatment during processing
 - Surface sanitation during clean-up
- **This will further reduce sanitation chemicals or provide an additional point of intervention for food-contact and non-food contact surfaces.**
- ***Listeria monocytogenes* is often found in drains. Regular use of an aqueous ozone system for floor surface sanitation has been shown to eliminate this occurrence.**

Case Study

Silver Star Meats

- Pennsylvania-based RTE meat processor
- Manufactures fresh and smoked pork sausage, bacon, skinless and natural-casing wieners, lunch meat, and hams
 - 25,000 pounds per day
- Preliminary testing with portable ozone surface sanitation system demonstrated ozone's effectiveness
- Implemented centralized ozone system for hard surface and direct product sanitation at a total cost of approximately \$50,000 (CCP is 2.0 PPM DO₃ @ 30 seconds (CT 1.0))
- Customer realizing \$124,000 annual savings by using ozone-enriched cold water instead of organic acid (sodium lactate)

Case Study – Silver Star Meats

Application Overview

- **Equipment sanitizer (hard surface)**
 - Pre-operational sanitation
 - In-process sanitation
- **In-process anti-microbial product wash**
 - Casing soak
 - Product spray
- **Post-lethality treatment**

Case Study – Silver Star Meats System Design

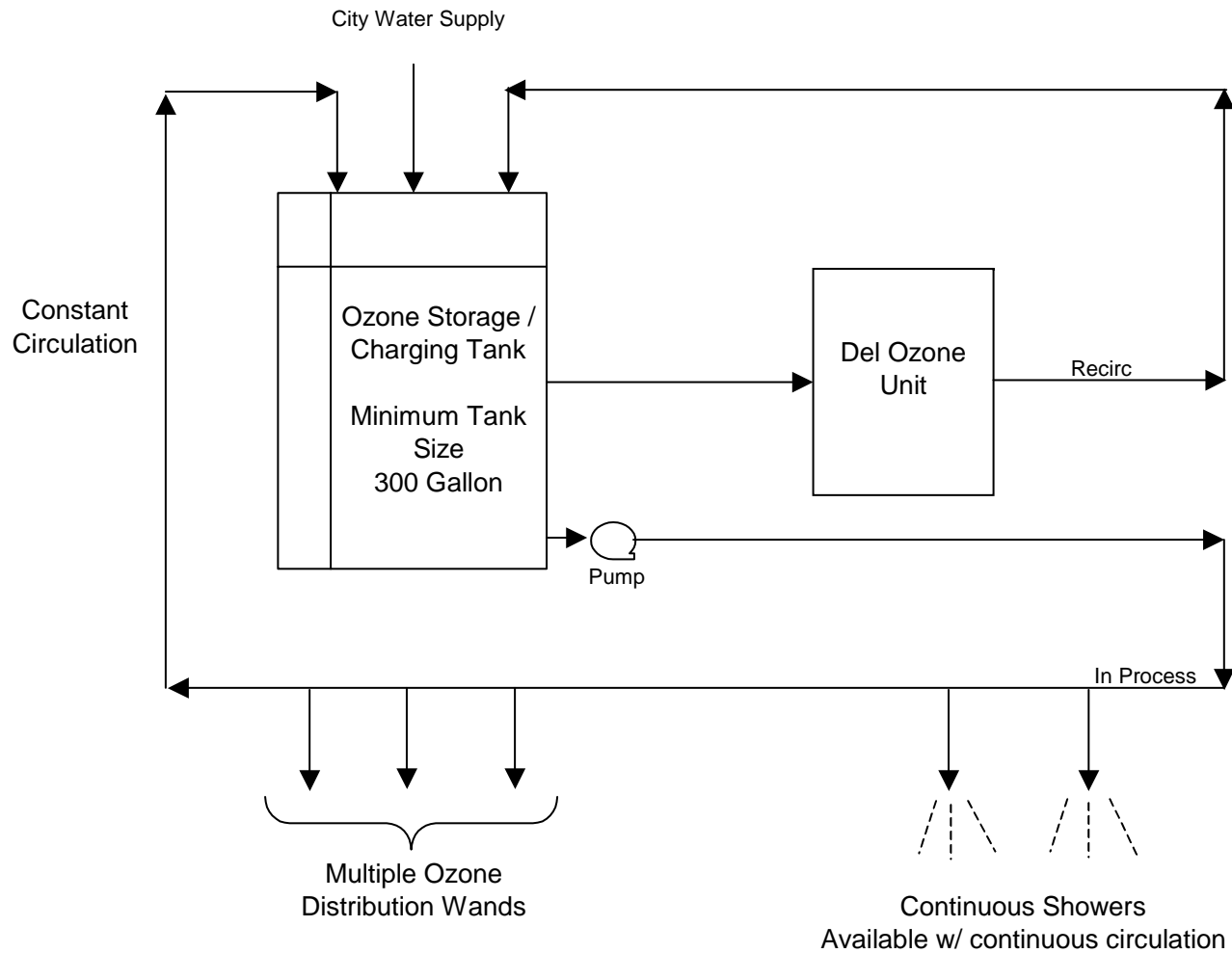

Case Study – Silver Star Meats System Design



Case Study – Silver Star Meats

Hard Surface Applications

- **Ozone has no residual effect**
- **Use in conjunction with a residual chemical sanitizer as necessary**
 - **Clean**
 - **Ozone Rinse**
 - **Quat @ 400 ppm**



Case Study – Silver Star Meats

Hard Surface Applications

- Results from pre-op (2003 vs. 2004) ATP Tests show ozone to be effective:
 - 79.96% reduction in ATP counts over 2003
 - 58.24% reduction in the number of swab failures over 2003

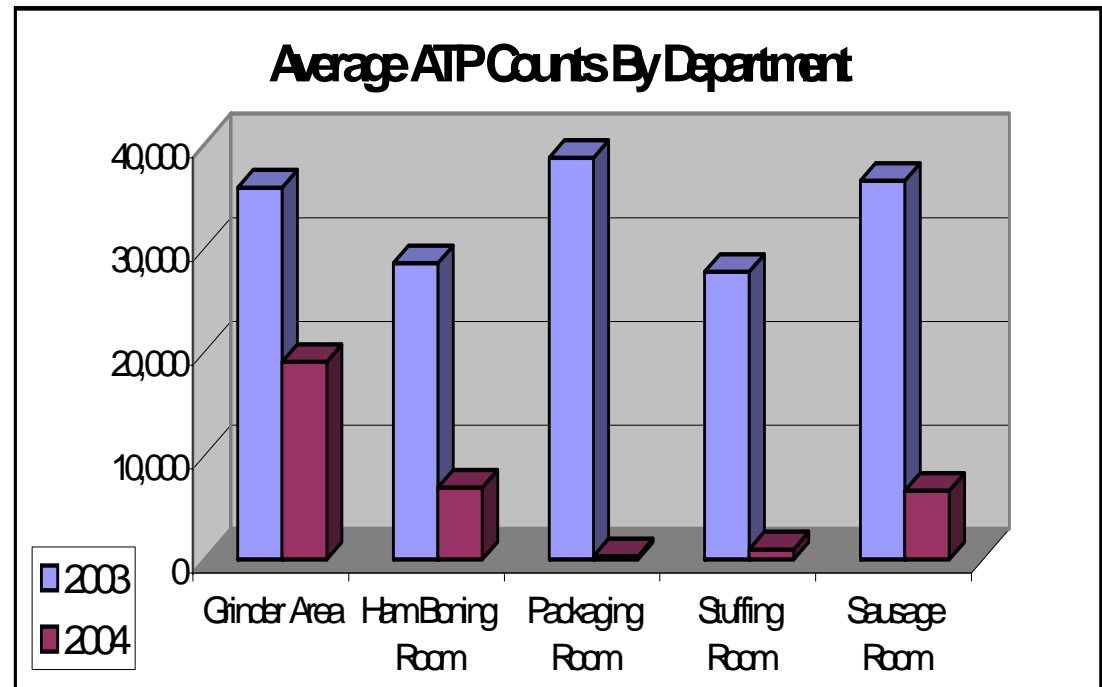

Case Study – Silver Star Meats In-Process Applications

- **Replace potable water sprays on belts**
 - Reduce/prevent bacteria build-up on production belts
 - Prevent product surface contamination



Case Study – Silver Star Meats In-Process Applications

- **Direct product application**
 - Reduce bacteria levels on product
 - Increase shelf-life



Case Study – Silver Star Meats

Post-Lethality Treatment

- Can be easily adapted for use on cutting equipment, belts, etc.
- Does not affect organoleptic quality of RTE meat products



Case Study – Silver Star Meats

Post-Lethality Treatment

- **Product Shower**
 - All product is showered directly before packaging



Additional Case Studies

Commercial User Testimonials

- **RTE Plant – surface sanitation (2.0 PPM, 30 sec.)**
 - Lazy Susan – 3 log reduction (bioluminescence analysis)
 - Bag Wall – 1 log reduction (bioluminescence analysis)
- **RTE Plant – surface sanitation (2.0 PPM)**
 - Eliminated Listeria in their drains
- **RTE Plant – direct contact on cooked roast beef (2.0 PPM, 30 sec.)**
 - Improved shelf-life over traditional chemicals
- **RTE Plant – direct contact on cooked ham, wieners (2.0 PPM, 30 sec.)**
 - Improved shelf-life over traditional chemicals
 - Complies to Alternative 2
- **Beef Filets – direct contact prior to packaging (0.75 PPM, 10 sec.)**
 - Lactobacillus control (eliminated package blow-up)
- **Sausage Plant – direct contact on trim (1.5 PPM, 1 min.)**
 - 2 log reduction (CFU count)
- **Beef Plant – direct contact on carcass (1.5 PPM, 30 sec.)**
 - 2 log reduction (CFU count)

Conclusion

- **Ozone is an authorized and validated anti-microbial agent.**
- **There are numerous uses for ozone in the meat manufacturing environment.**
- **It is important to review your specific plant layout and requirements to determine where and how ozone can best be used in your facility.**

Thank You